



# DIE CUSHION SYSTEM ADAPTED TO SERVO PRESS

## MOST RELIABLE DIE CUSHION SYSTEM FOR SERVO PRESS

### FEATURES

#### 1. POSITION LOCK ENABLED!

...Position lock at BDC became possible which was difficult with pneumatic die cushion.

Accuracy of locking position is improved to meet servo press requirement.

#### 2. CUSHION FORCE IS MAINTAINED ANY POSITION!

...Ordinary die cushion may lose its force when slide is stopped. Our system maintain cushion force.

#### 3. Enable to reduce pressure at any position!

...Cushion force can be reduced during slide in motion.

This provides most suitable forming and protection of products.

#### 4. EASY CUSHION FORCE ADJUSTMENT!

...Adjustment of cushion force can be achieved easily through remote control relief valve.

### SPECIFICATIONS

Maximum cushion force	KN	150	300	400				
Cushion force adjusting range	KN	30~150	55~300	75~400				
Cushion force reduction adjusting range	KN	30~150	55~300	75~400				
Knock out force adjusting range	KN	30~150	55~300	75~400				
Cylinder stroke	mm	120						
Cylinder diameter	mm	φ 100	φ 140	φ 160				
Pressure area	cm <sup>2</sup>	78.5	153.9	201.1				
Slide speed at forming (MAX)	mm/sec	290	150	115				
Required oil volume for Knock out @	q (60Hz)	63	80	63	80	63	80	
	q (50Hz)	52	67	52	67	52	67	
Required oil volume for Knock out @ high-load	q (60Hz)	4						
	q (50Hz)	4						
Knock out force	low-load	KN	Less than 29	Less than 24	Less than 57	Less than 46	Less than 74	Less than 60
	high-load	KN	same as the Die cushion force					
Theoretical knock out speed (@high load)	(60Hz)	mm/sec	8	4	3			
	(50Hz)	mm/sec	8	4	3			
Theoretical knock out speed (@low-load)	(60Hz)	mm/sec	134	170	68	87	52	66
	(50Hz)	mm/sec	110	142	56	73	43	56
Operating Voltage	V	200VAC 50/60Hz						
Electric motor capacity (for main motor)	KW	5.5KW-4P						
Electric motor capacity (for cooler)	KW	0.75KW-4P						

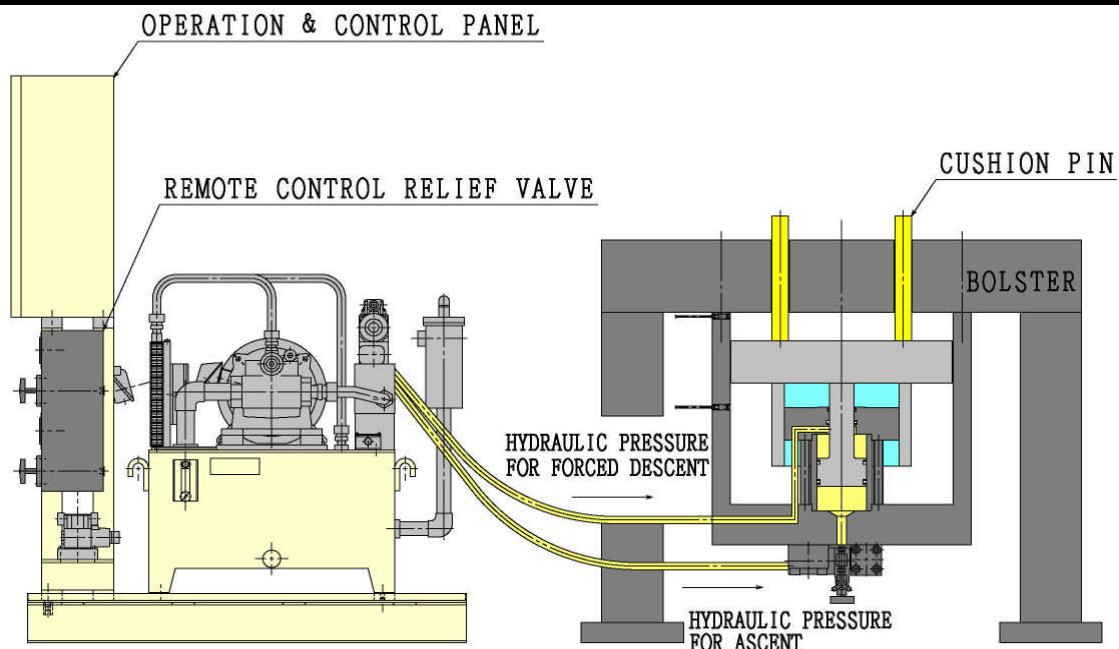

## ■Dimensions

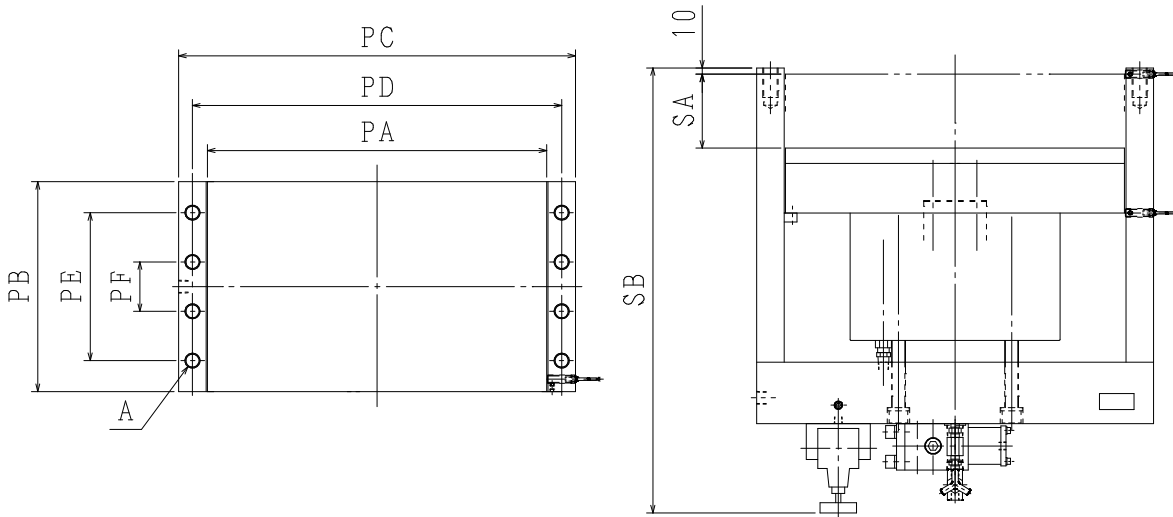

Die cushion type	PA	PB	PC	PD	PE	PF	A
150KN	250	250	326	290	150	-	4-M20
300KN	540	340	632	588	240	-	4-M24
400KN	540	340	632	588	240	80	8-M24

Die cushion type	SA	SB
150KN	120	670
300KN	120	710
400KN	120	720

## ■Schematic

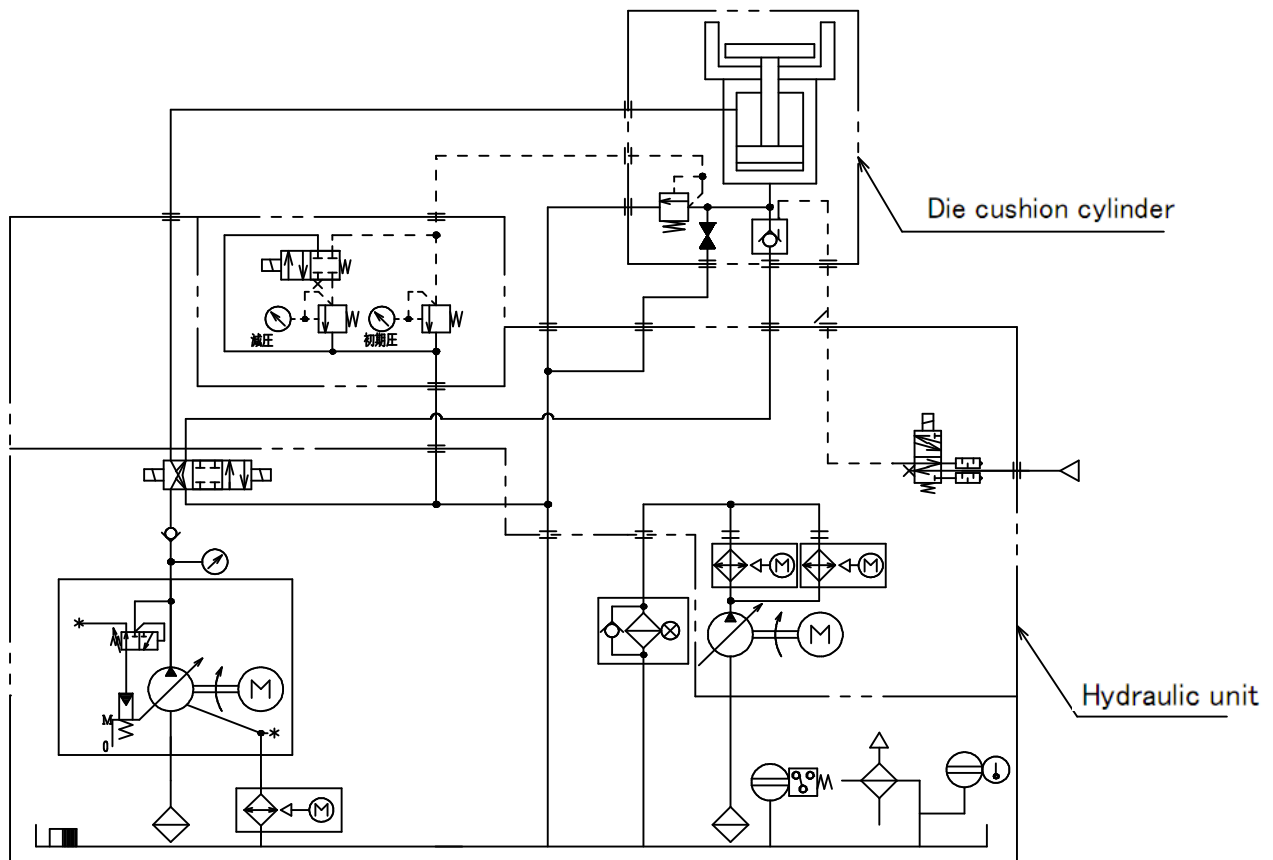

**SR ENGINEERING CO., LTD.**

'2-60, 3-CHOME TAKATSUKA-DAI NISHI-KU, KOBE, JAPAN  
TEL: +81-78-991-4400 FAX: +81-78-991-4406

URL <http://www.sr-engineering.co.jp>

E-mail; [srke@sr-engineering.co.jp](mailto:srke@sr-engineering.co.jp)

## Frequency that can be molded

The frequency of each stroke that can be molded is described in the following table according to the output. Please use it by a frequency that is less than the frequency that can be molded.

This graph shows the case where the cylinder of each output is used.

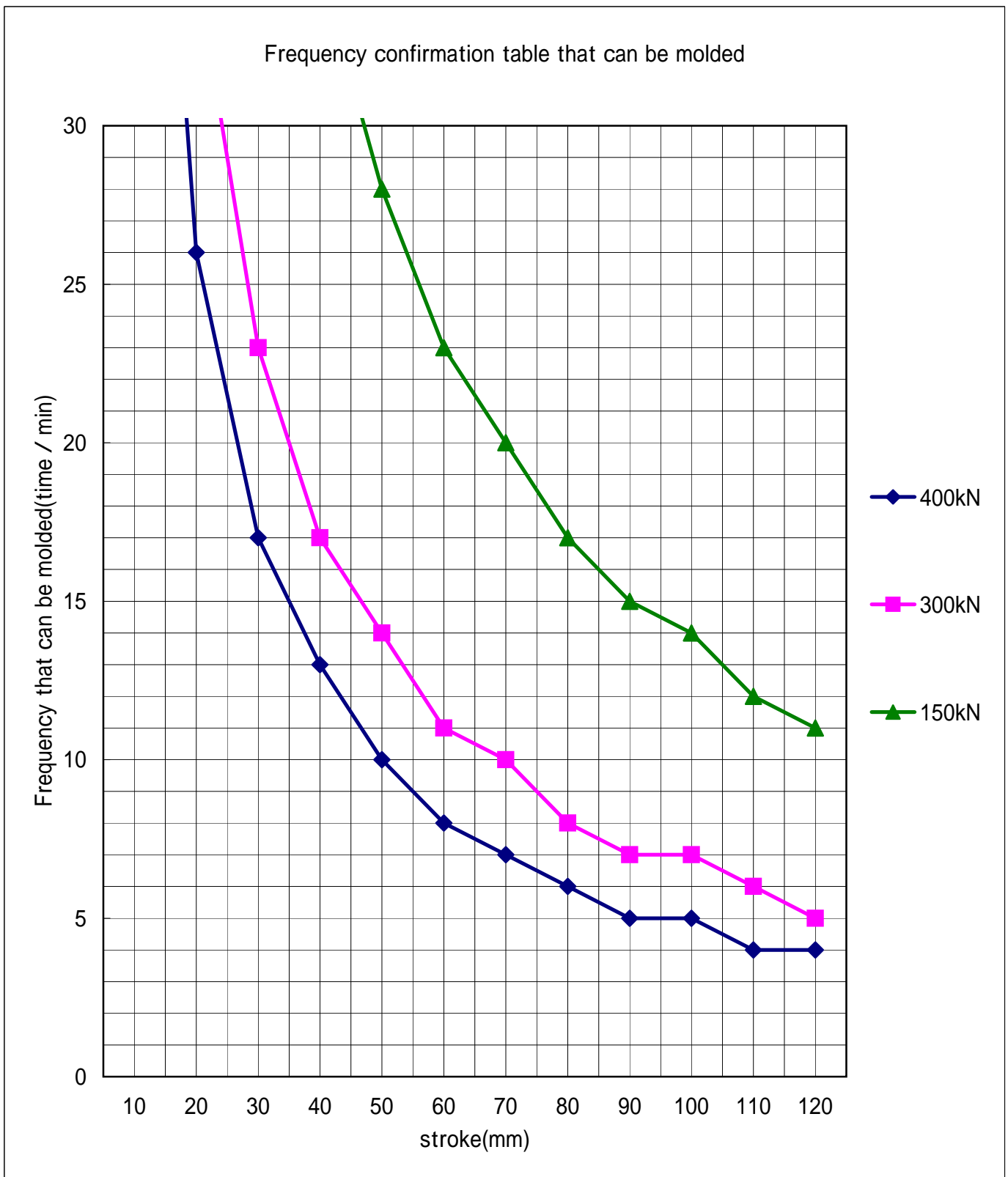

### SR ENGINEERING CO.,LTD.

HEAD OFFICE · DEVELOPMENT CENTER / 2-60, Takatsukadai 3-chome, Nishi-ku, Kobe, 651-2271 Japan  
SALES: TEL.(078)991-4400 FAX.(078)991-4406 DEVELOPMENT CENTER: TEL.(078)991-4407 FAX.(078)991-4403  
TOKYO BRANCH/Sansin.2F 2-21-12,Hachiman-cho,Fuchu-City,Tokyo,183-0016 Japan  
TEL.(042)369-6401 FAX.(042)369-6404  
CHUBU BRANCH 45,Takyo-cho 4-chome,Toyota,Aichi,471-0077 Japan  
TEL.(0565)32-3081 FAX.(0565)32-3083

URL <http://www.sr-engineering.co.jp>

E-mail ; [sre@-engineering.co.jp](mailto:sre@-engineering.co.jp)

# 1. FEATURE

1-1. Even if the slide stops, cushion force is maintained.

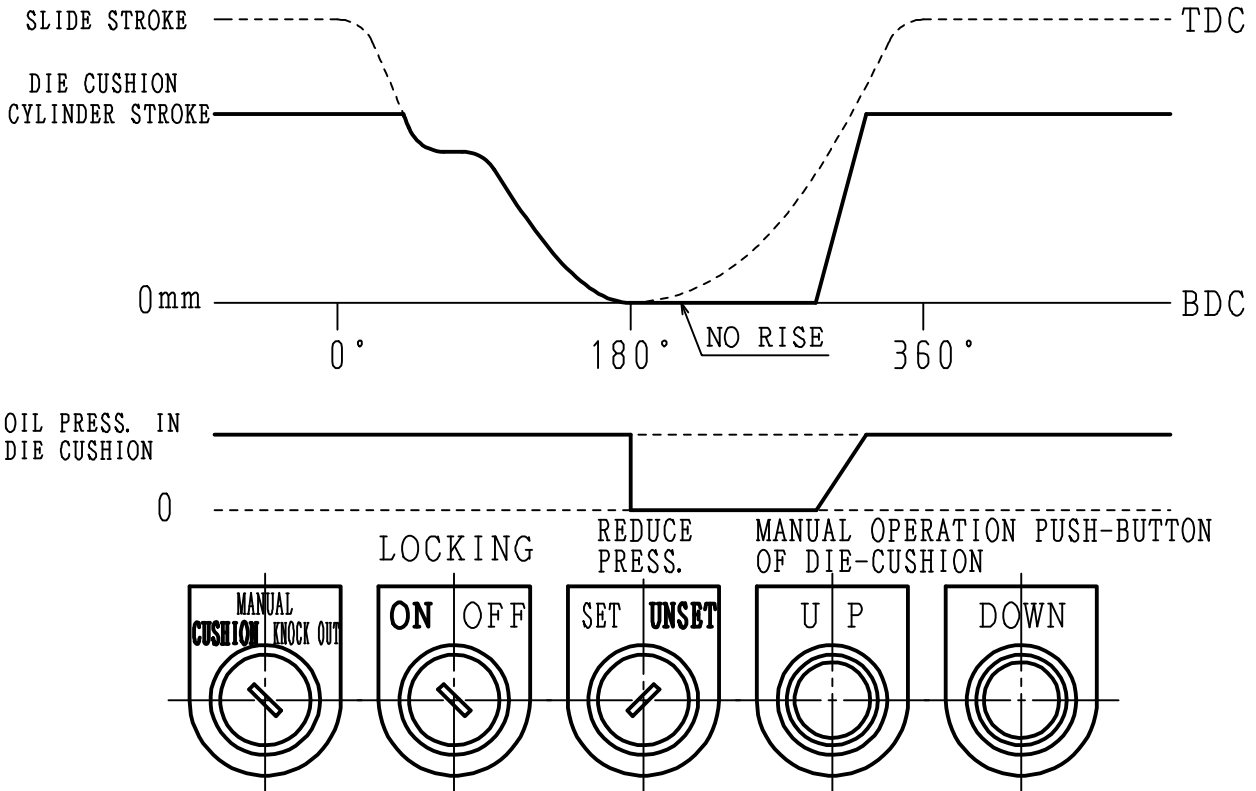

1-2. Enable to reduce pressure at any position.

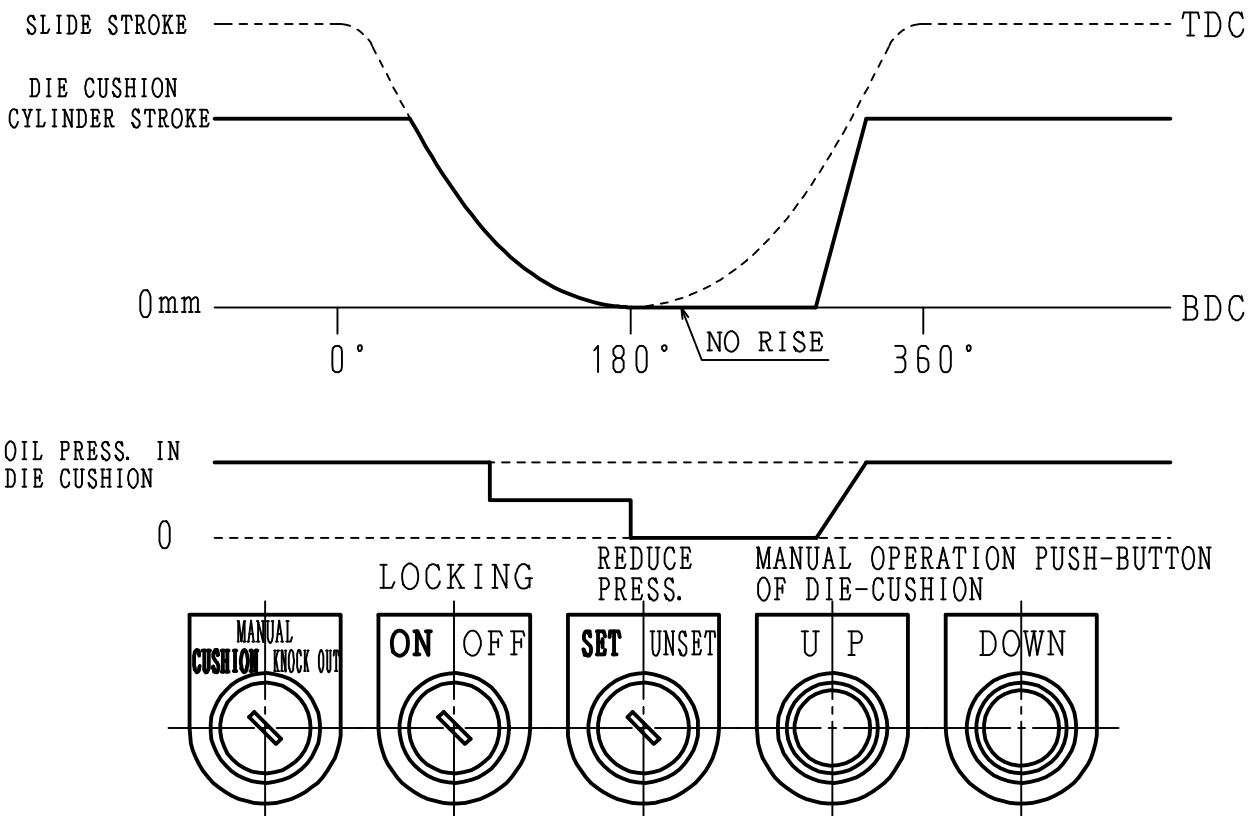

### 1-3. Locking or follow can be selected at pulse molding.

#### 1-3-1. Locking

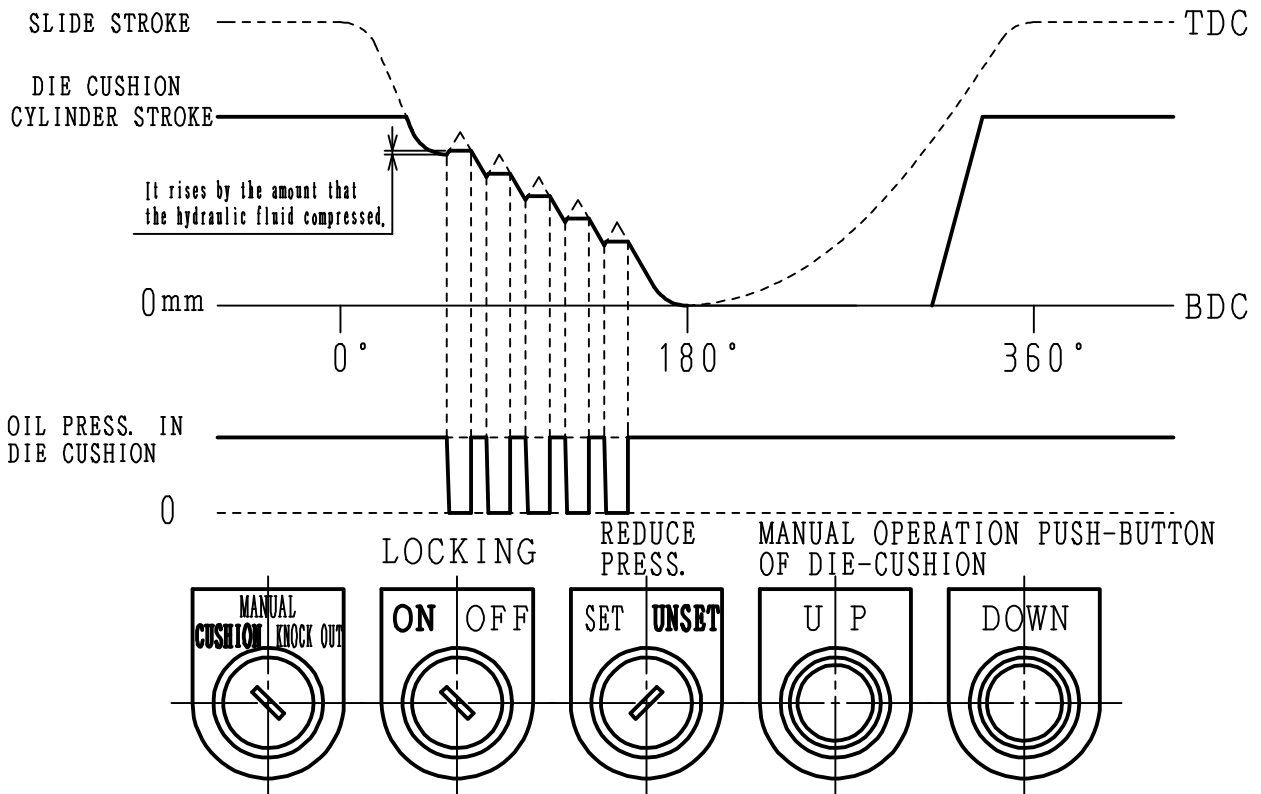

#### 1-3-2. Follow

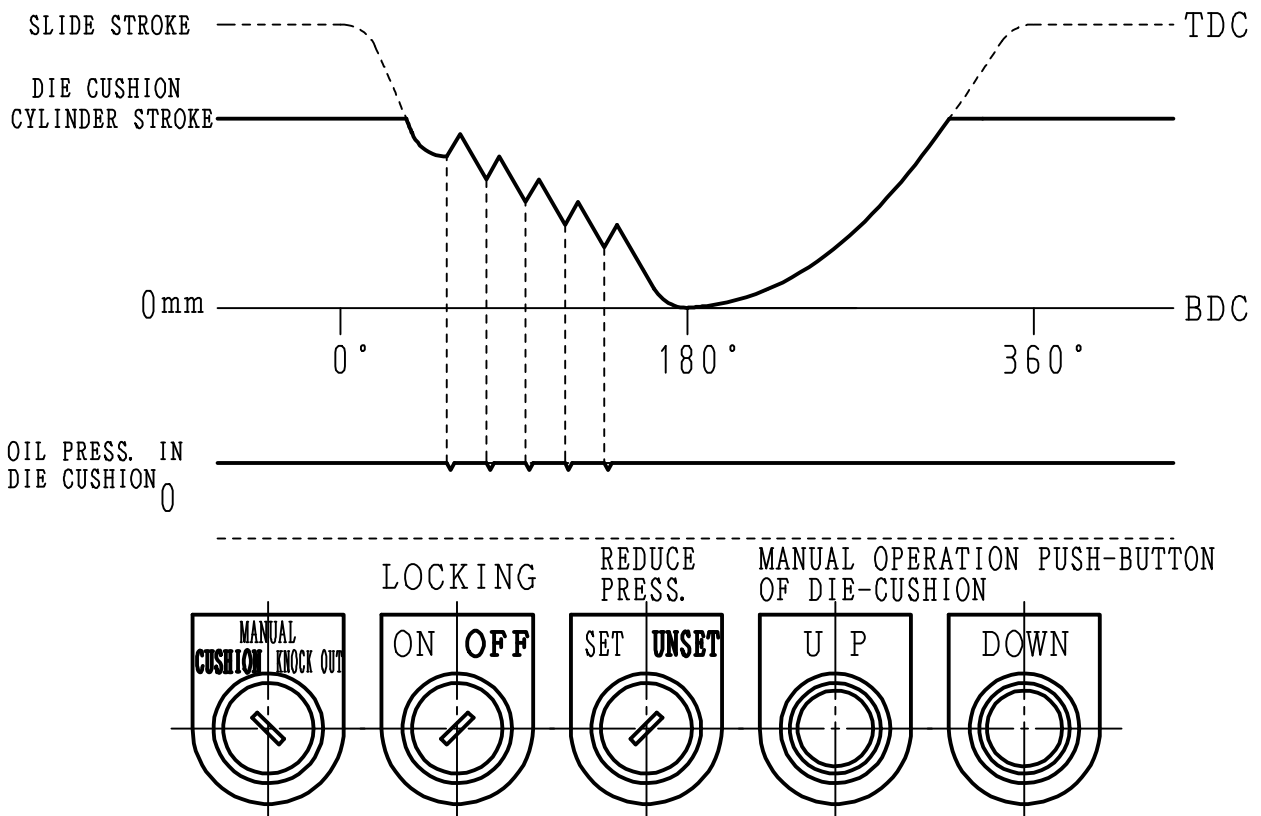

# 2. MODE OF OPERATION

## 2-1. DIE CUSHION to which pressure always hangs

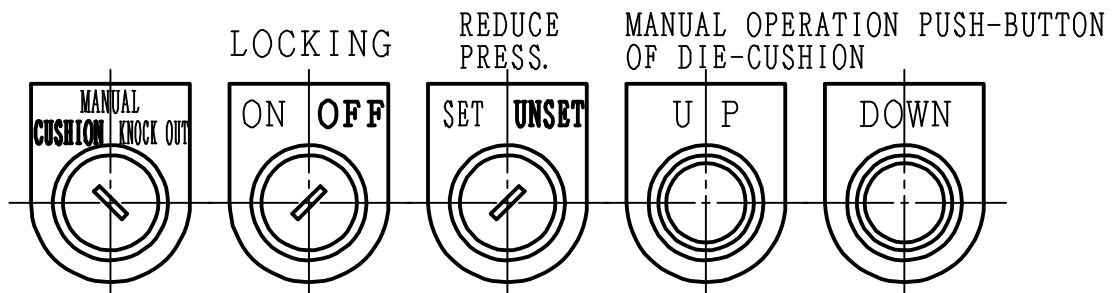
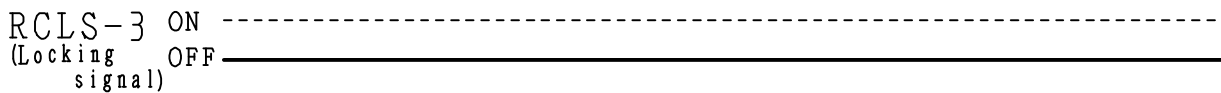
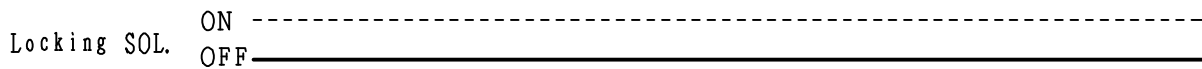
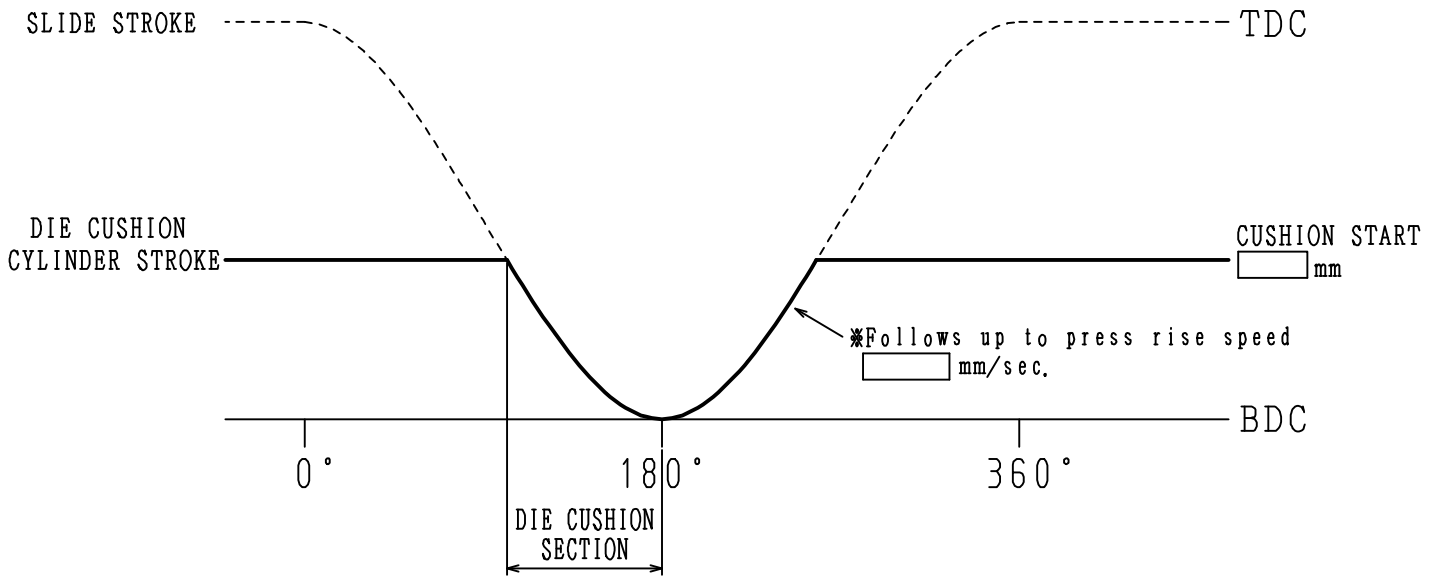

## 2-2. Die cushion with locking

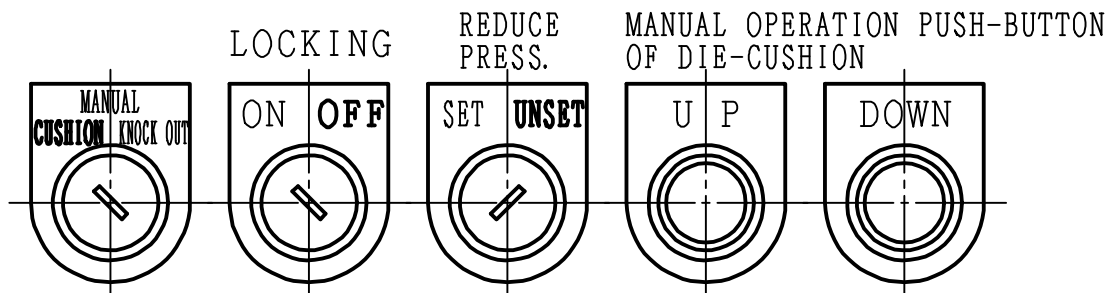
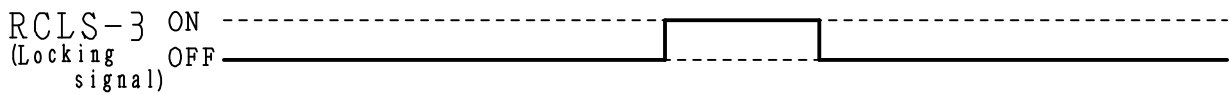
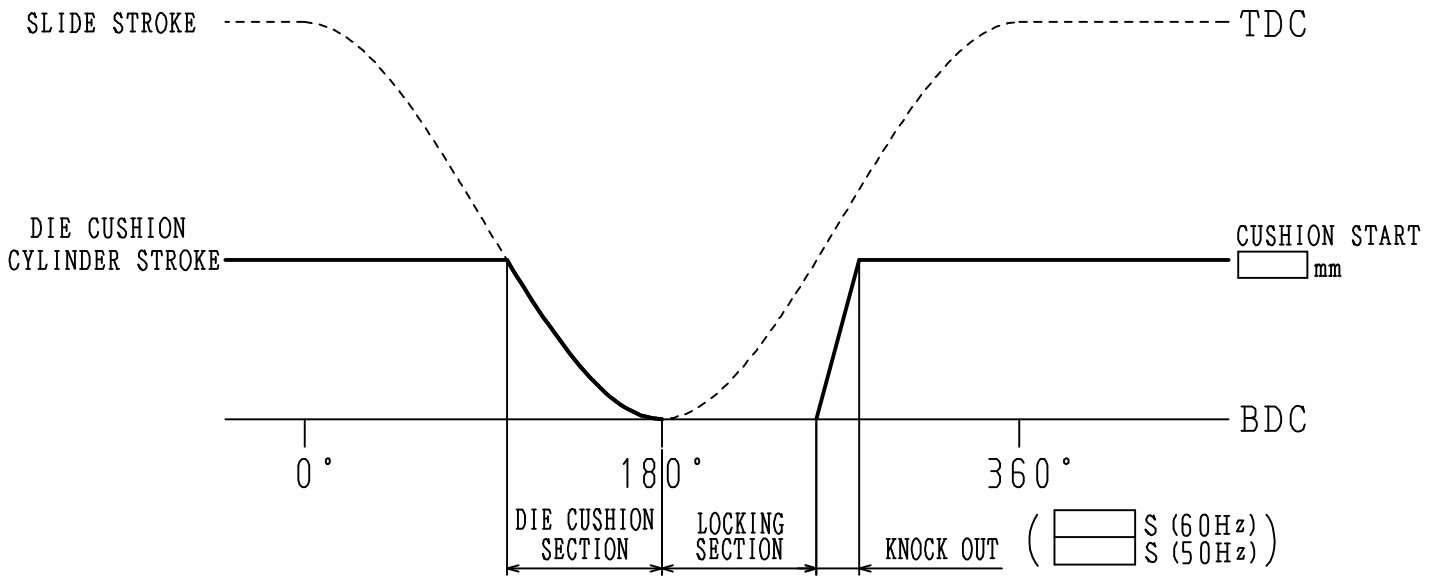

## 2-3. Knock Out

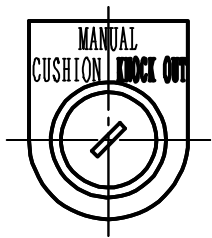
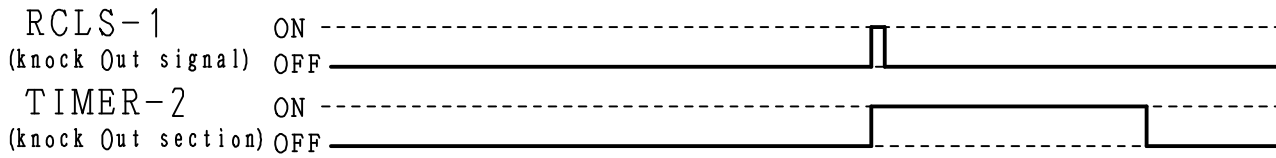
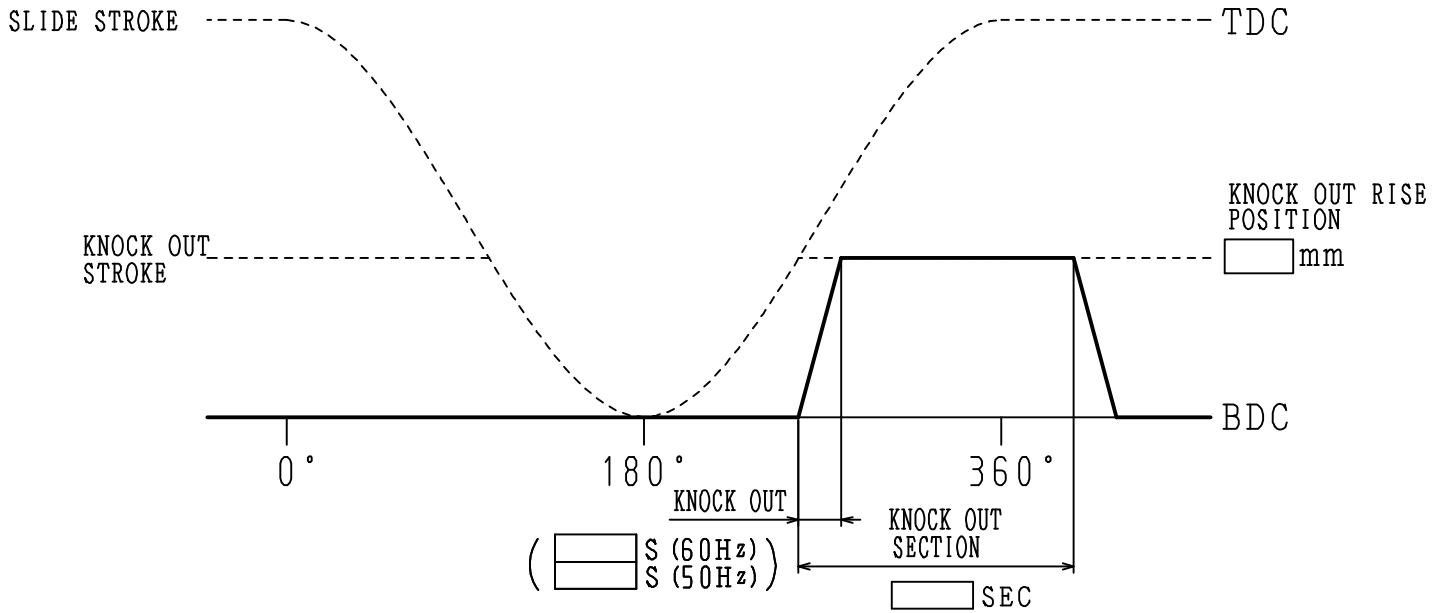

## 2-4. Manual

•Slide position is TDC.

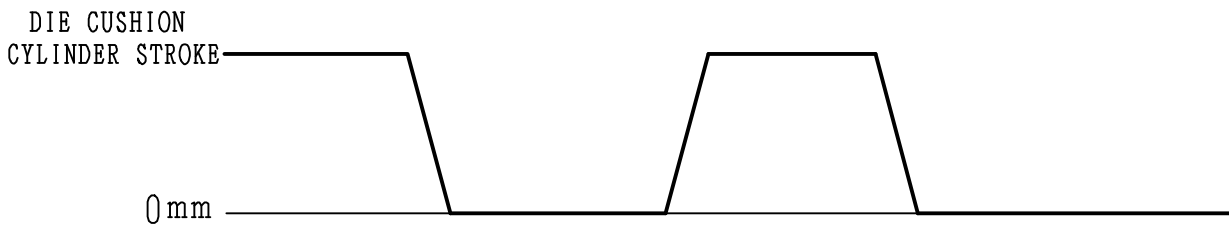

Manual operation button

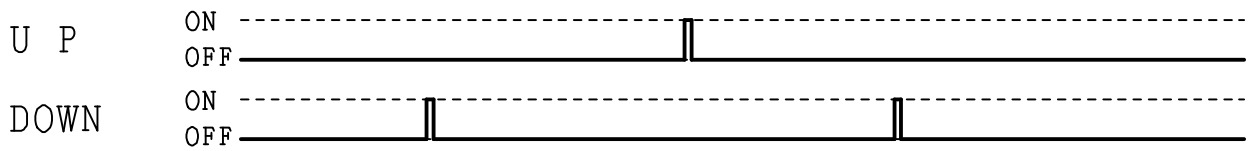

MANUAL OPERATION PUSH-BUTTON  
OF DIE-CUSHION

