

SFZ

可调型一手持式夹紧器 24.5MPa 系列



特点

FEATURES

- 本体结构为单作用式油缸，松开靠弹簧作用更换。
- 具有重量轻，结构紧凑，坚固耐用等优点。
- 进油口可选择NPT1/4。
- Single acting, spring return cylinder, suitable for pulling and pushing,
- Light weight, compact and robust
- NPT port type is available as option.

参数

SPECIFICATIONS

参数	型号	SFZ2	SFZ4	SFZ6	SFZ10	SFZ16
耐 压 Proof pressure	MPa	36.8				
最大工作压力 Maximum working pressure	MPa	24.5				
最大夹紧力 Maximum force	kN	21.5	40	59.8	98	164
总行程 Stroke	(mm)	8	8	8	8	8
所需油量 Required volume of oil	(ml)	7.5	13.9	20.7	33.1	56.9
使用温度 Ambient temperatures range	(°C)	-5~60				
使用油 Recommended fluid		一般液压作动油(VG32~VG56) General hydraulic fluid (ISO VG32~VG56)				
重量 H型/B型 Mass H hole/B hole	(kg)	08/09	12/13	21/22	36/38	66/69
使用频率 Frequency limit		25回/日以下 25Times/Day				
耐冲击 Shock limit		300m/s ²				

形状及尺寸

SHAPE AND DIMENSIONS

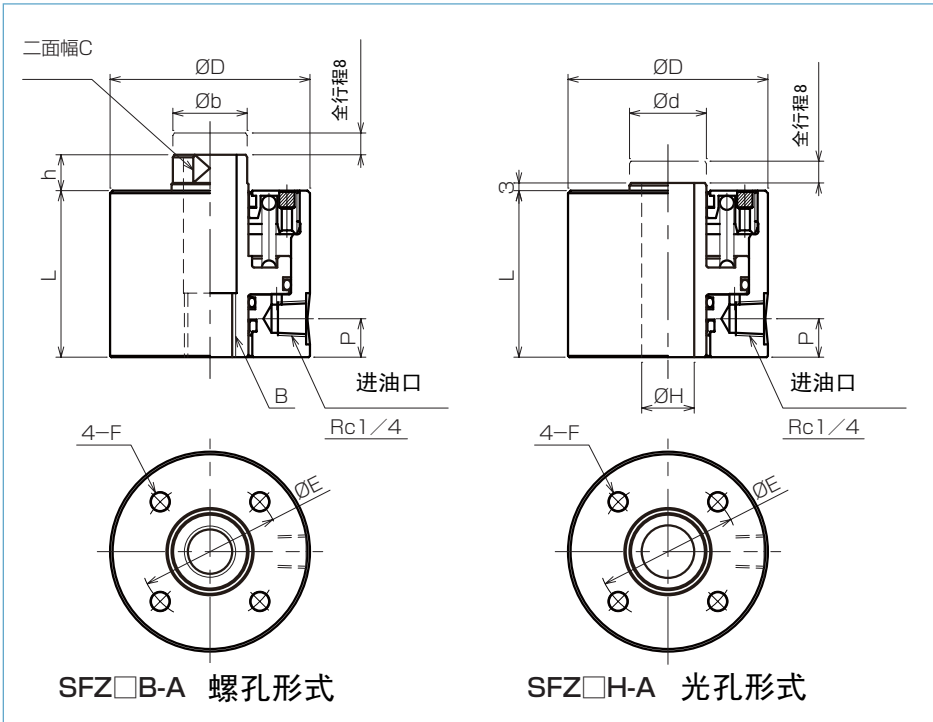

型号

TYPE DESIGNATION

SFZ **1** **e** -A

① 公称夹紧力 (at 24.5MPa) Nominal force

2	21.5kN
4	40.0kN
6	59.8kN
10	98.0kN
16	164.0kN

② F 孔的形状

B	螺纹形式	Screw type
H	光孔形式	Hole type

型号 TYPE	DIMENSIONS 尺寸	D	L	P	b	h	C	B	d	H	E	F
SFZ2□-A		54	52	13	17	12	15	M12×1.75 螺纹长度24 M12×1.75 Length 24	18	12.5	40	M6 深11 M6 Depth 11
SFZ4□-A		62	58	15	23	12	19	M16×2.0 螺纹长度30 M16×2.0 Length 30	24	16.5	48	M8 深15 M8 Depth 15
SFZ6□-A		78	65	15	29	14	26	M20×2.5 螺纹长度30 M20×2.5 Length 30	30	20.5	58	M8 深15 M8 Depth 15
SFZ10□-A		98	71	15	39	20	35	M24×3.0 螺纹长度36 M24×3.0 Length 36	40	24.5	80	M8 深15 M8 Depth 15
SFZ16□-A		126	78	15	49	23	41	M30×3.5 螺纹长度45 M30×3.5 Length 45	50	30.5	100	M8 深15 M8 Depth 15

SR ENGINEERING CO., LTD

www.sr-engineering.co.jp/

公司总部

地址: 2-60 3-CHOME, TAKATSUKADAI, NISHI-KU KOBE, JAPAN 651-2271

电话: +81-78-991-4400

传真: +81-78-991-4406

邮箱: sre@sr-engineering.co.jp